









Research Article

Empowering Aquarists a Comprehensive Study On IOT-Enabled Smart Aquarium Systems For Remote Monitoring And Control

M.Sahaya Sheela^{1*} , S.Ravi Chand² , S.Gopalakrishnan³ , Shruti Bhargava choubey⁴ , M Gopianand⁵ , J.Jasmine Hephzipah⁶ 

¹Department of Department of Electronics and Communication Engineering , Vel Tech Rangarajan Dr. Sagunthala R&D Institute of Science and Technology, Chennai, Tamil Nadu, India.

²Department of Electronics and Communication Engineering Nalla Narasimha Reddy Education Society's Group of Institutions Integrated Campus, Hyderabad-500 088,India.

³Department of Information Technology,Hindustan Institute of Technology and Science (Deemed To Be University), Kelambakkam, Tamil Nadu 603103, India.

⁴Department of Electronics and Communication Engineering, Sreenidhi institute of science and technology, Yamnampet,,ghatkesar,Hyderabad, 501301, India.

⁵Department of Computer Applications, PSNA College of Engineering and Technology, Dindigul 624622.Tamil Nadu,India.

⁶Department of Electronics and Communication Engineering, R.M.K. Engineering College, Kavaraipettai, Tamil Nadu 601206, India .

ARTICLE INFO**ABSTRACT**

Article History

Received 10 Mar 2024

Accepted 17 May 2024

Published 11 Jun 2024

Keywords

PH

Temperature

Turbidity

ESP32

Thingspeak.



Nowadays, a lot of people keep fish as pets at home and the aquarium keeper has been feeding the fish in the tanks, therefore appropriate setup and upkeep are required. Taking care of the aquarium appears to be somewhat tough for aquarists. The fish's quality of life depends on the aquarium being kept up properly. Changes in water quality, fish feeding, temperature management, light control, and the challenge of physically inspecting aquarium conditions are these problems are experienced.. As such, it is important to monitor the physical characteristics regularly and to improve the quality of the water. It has water quality management, which levels the aquarium to the perfect conditions by keeping an eye on the physical variations in the tank. Thus, the system that this model suggests is capable of real-time operation and is fitted with sensors. It carries out turbidity system, water renewal, temperature monitoring, and pH level detection in water and all these things are carried out in the ESP32 controller which contains an inbuilt WiFi module. For large-scale aquaculture, an embedded system with a wireless network technology and a water quality testing unit was proposed. The aquarium's state is tracked and sent to the user's mobile application via Thingspeak IoT platform.

1. INTRODUCTION

The most common type of aquarium used to keep freshwater or saltwater aquatic life is an aquarium tank. An aquarium, then, is a place that houses a variety of aquatic creatures, most of which are kept for research or exhibition. Fish are the main components of an aquarium, along with other decorations such displayed pebbles. Enormous aquarium designs are available for study, and these typically feature enormous aquatic animals like sharks, etc.

Conventional aquarium monitoring involves visual inspection of fish health and behavior as well as routine manual sampling of water quality measures. Water samples are taken by aquarium owners, who then analyses them for various factors, including temperature, pH, ammonia, nitrite, and nitrate. They visually examine the fish to look for indications of stress or disease. Usually, the information gathered by this method is manually entered into a spreadsheet or logbook.

Maintaining the well-being of fish in aquariums presents a number of factors for aquarists such as while fish keepers are away from their tanks or while they are travelling, feeding the fish may be a challenging undertaking. For fish to have a healthy life, the temperature and salinity of the water must also be regularly monitored. If the amount of suspended fish

*Corresponding author. Email: hisheelu@gmail.com

particles is greater than the allowable limit, the water must be changed to reduce its high turbidity. For fish to breathe easily, the oxygen flow inside the water must be observed. Therefore, a system for ongoing observation, management, and fish care must be devised.

The model is proposed to eliminate all the problems in the traditional aquarium monitoring system. The model consists of determining the PH level of the water, the temperature of the water, and the turbidity level of the water. And the operations like the automatic disposal of polluted water and the refilling of the tank with pure water. Continuous monitoring and displaying the status of the water on display and the IoT platform.

The sensors, actuators, and controllers are used in the model, such as the PH sensor for monitoring the PH level of the water, the DS18B20 temperature sensor to monitor the temperature of the water, and the turbidity sensor to monitor the pollutant level of the water. The actuators, such as the relay to turn on the motor during cleaving and refilling of the tank and the LCD display to display the parameters such as PH, temperature, and turbidity level of the water, And the parameters are also displayed on the Thing speak IOT platform.

1.1 Objective:

- To monitor the water parameters such as PH, Temperature and turbidity.
- To develop an automatic cleaning and refilling system.
- To show the parameters in the local and the IoT platform.

2. LITERATURE SURVEY

The detection of water parameters such as pH level, temperature, and dissolved oxygen level and ammonia levels, which are crucial for fish farming in the correct water. An android operating system based mobile application has been developed to notify fishermen, farmers, and aquaculture-related individuals about these parameters. Bangladesh, a riverine country, heavily relies on fish farming for its economy and the fisheries in Bangladesh are not experts in providing necessary elements to fish. The work can help fish farmers measure these parameters and provide the necessary elements to grow more fish. This would help maintain good health and ensure the success of fish farming in Bangladesh, a state with a significant impact on the economy. [1]

The water quality monitoring system using Arduino and Raspberry Pi 3B+ through LoRaWAN IoT Protocol to monitor and maintain essential water quality parameters for fish farming. The sensors, microcontrollers, and web application are to acquire and monitor data on water quality parameters. The aquarium is maintained at optimal levels using an aquarium heater, mechanism for sodium bicarbonate distribution, and water pump. Two intensive aquaculture setups—controlled and conventional—were monitored in order to gauge the effectiveness and dependability of the aquariums. The controlled setup outperformed standard setup produce quality, greatly enhanced efficiency, decreased labour for fish farmers, and prevented fish deaths. [2]

An IoT-technology based system that monitors and controls water quality in fish tanks, ensuring the best environment for aquatic life. Factors such as water oxygen level, pH level, temperature, and cleanliness were considered to maintain the best conditions for aquatic life. fish keepers and aquarists in maintaining fish tanks, which require significant energy and time, were assisted and It will introduce a water monitoring system, self-feeding, and water self-replacement mechanisms to reduce the manual labor required for tank maintenance. Sensors such as temperature, turbidity, level, and pH sensors will be integrated to monitor water quality, ensuring a safe environment for fish. A self-refilling and self-feeding mechanism, which users can remotely control and monitor through their mobile devices using IoT technology, was implemented. [3]

Taiwan faces significant aquaculture losses due to typhoons and cold snaps, and human resources are a challenge. Wireless data transmission technology using sensors to transmit temperature, dissolved oxygen, pH value, water level, and life anticipation data to servers. This data is then transmitted to smart communication devices via the Internet of Things, allowing manager to monitor water quality on fish farms. A robotic arm was developed by a programmable logic controller in a single chip, a wireless data transmission module, and with an embedded system for automatic measurements and maintenance. The arm can work 24/7, reducing losses due to human error, material resources, and data errors. [4]

Real-time and continuous monitoring of aquatic parameters is crucial for fish farmers, and the Internet of Things (IoT) could play an important role. An IoT support for effective monitoring and control of various aquatic ecological parameters related to water. An embedded system using sensors are connected to a common microcontroller board built

on an Arduino Uno was implemented. The sensors to read data from the water and store those data as a CSV file in an Internet of Thing cloud named ThingSpeak and after collecting data from five ponds, only three were considered perfect for fish farming, meeting standard reference values of pH, turbidity, temperature, conductivity, and depth. An IoT basis for a real-time aquatic conditions monitoring system was implemented by using proper hardware. [5]

Aquaculture is a significant industry in Malaysia, with a focus on improving water quality for locals and increasing the economy. Water quality parameters suitable for various aqua cultural species, particularly fish, were measured by using the five smart sensors, including a waterproof DS18B20 temperature sensor, water PH sensor, water turbidity sensor, air temperature sensor, and light sensor, placed in a fish tank to monitor variations during feeding time. These sensors are connected to an Arduino board, which transmits collected data to the GSM and ThingSpeak cloud for 24-hour monitoring. The sensors are chosen to clarify the statistical correlation between air temperature and water temperature, light intensity, turbidity, and PH, especially during feeding time. [6]

Water quality in fish breeding tanks is crucial for successful growth. To ensure optimal water quality, an IoT-based monitoring system is essential. Jade Smart 1.0 is an IoT-based system that consists of three boxes connected with ESP32 microcontrollers, pH, temperature, and turbidity sensors. The system collects, stores, and displays water quality data through web and mobile phone applications. The output showed an average pH level of 6.48 at 10cm depth, a temperature of 28.6°C at 10cm depth, and a turbidity of 3.3 NTU at point A. The difference was 0.3% at the least and 2.6% at the greatest. Measurements of the water temperature at various depths show a maximum variation of 1.7% and a lowest variation of 0.3%. [7]

An automatic aquarium system using real-time Internet of Things control using Arduino and ESP 32 microcontrollers contains a water parameter monitoring, feeding system, and a water change system. A user-controlled feeding system prevents overfeeding by adjusting food quantity, while a water quality monitoring system ensures optimal temperature level and pH levels. When water parameters exit optimal conditions, actuators will be turned on to restore them. Those parameters are displayed on a web and mobile application platform, providing real-time streaming and live situation updates. [8]

Automated aquarium monitoring systems are popular due to their ability to control various aspects of the aquarium's environment, such as pH, temperature, turbidity, water level and feeding. These systems are time-consuming and require significant commitment, so an IoT-interfaced system is needed to control and monitor the entire aquarium maintenance process using electronics and sensors that constantly communicate and transmit real-time status to the user's smartphone. The automatic adjustment of the water's conditions ensures optimal conditions for the fish. Manual effort required for aquarium management, making it a more efficient solution, is reduced. [9]

Fish farming has rapidly grown due to the application of modern technologies and community structure changes, and monitoring and controlling feeding activities is crucial for fish health as overfeeding and starvation can lead to reduced water quality in house hold tanks. The fish feeder system on ESP8266 microcontroller with a built-in Wi-Fi unit allows fish owners to monitor their tanks, set feeding schedules, and monitor water quality using turbidity and pH sensors. The Blynk-app mobile application is being tested for a reliable real-time monitoring system for all Android and iOS fish feeder users. [10]

A new IoT-based aquarium monitoring system is being developed to address dead marine life issues like prawns and fish. The mobile apps "Blynk" and Arduino IDE to connect to a NodeMCU aquarium microcontroller and the ESP8266 NodeMCU with the right sensor type to monitor pH, temperature, and water levels are used. This dosing model is suitable for aquaculture and home aquariums, encouraging users to prepare for maintenance like water changes and filtering devices. The Aquarium Monitoring System utilizes the affordable NodeMCU ESP8266 Wi-Fi module, which can be used for multiple sensors, making it suitable for various sensor types. It is also compatible with Blynk apps using Arduino IDE coding, providing users with an advantage in this marine application. [11]

A smart fish tank developed by STC89C52 as the core controller is embedded with an ultrasonic distance measurement sensor and DS18B20 waterproof temperature module. Remotely collect and control water and temperature levels through a WiFi module (ESP8266-01). If water levels are below the default, the system adjusts by adding water. The microcontroller is connected with the internet through a WiFi module, which compiles Python programs for data transfer. Android smartphones can also connect to the system via WiFi, allowing for remote control and ensuring water temperature and level stability. [12]

Aquaponics, a combination of hydroponics and aquaculture, uses an IoT system to collect agricultural and ecological data. An aquaponics work including a planting area and fish tank, was developed and an IoT aquaponics monitoring system was created using Arduino, WiFi shields, and Android applications. Data is collected using pH sensors, temperature sensors, and servo motors on the Favorite IoT platform. An average performance of 92.5% in providing notifications on water temperature, moisture, and pH was achieved. [13]

Popular in Indonesia, arwana fish are ornamental fish with high aesthetic value. Brazil's Silver Arowana fish is a freshwater ornamental fish that has problems with feeding, spawning, illness, and water quality. Aquaculture faces several challenges when it comes to managing water quality since parameter assessment takes time, involves steps, and requires several stages. Fish survival can only be maximised by developing IoT-based information technology 4.0, which will enable real-time monitoring of water quality. The study, carried out at the Vocational School of IPB in association with CV Viez Aquatics, is to develop an Internet of Things-based Water Quality Monitoring System (SIMONAIR) and utilise it to facilitate the growth of arowana fish. [14]

Modern IoT technology based fish farming systems may maximise the output of seafood by reducing resource consumption and enhancing the growth of healthy fish. A predictive optimisation method based on the Internet of Things for effective energy management and control in intelligent aquaculture. Fuzzy logic control is utilised to determine control settings for IoT actuators based on expected optimal water quality parameters, minimising energy usage. Indoor and outdoor data are used to forecast water quality parameters for an ideal fish growing habitat. The results demonstrated that, even at the highest actuator control rate, the predictive optimisation module was able to maintain water quality parameters at the ideal level while achieving over 30% energy efficiency. [15]

A water quality monitoring system was developed by pH, temperature, and TDS levels, so the fuzzy logic algorithm used to predict disease potential and a GUI was created to test the system's effectiveness. Blynk apps and Arduino Uno Wi-Fi R2.0 were used to keep informed the aquarium water quality in present. Hydroponic method was used to recirculate the water in fish tank. The aquaponic system regulates water tank parameters, ensuring Betta Splendens are free from diseases. [16]

A smart electronic system is designed to prevent water quality problems in fish culture and help fish farmers maintain optimal water quality for optimal fish production. A controller, water pump, solenoid valves, servo motors, GSM module, temperature, dissolved oxygen, pH, and turbidity sensors, a liquid crystal display, and the Arduino Mega 2560 controller are used. The bottom dirty water is replaced with clean, oxygenated water, replenishes ponds during water shortages, and adjusts temperature, DO, and pH levels. It also provides information about water quality and preventive maintenance to pond or tank operators via an app on a smartphone. It prevents air pollution and contamination of land, water bodies, and crops associated with poor-quality water. [17]

The development and survival of farmed species depend on the water quality in recirculating aquaculture systems (RAS); farmers determine the water quality indicators to observe, and there are no set criteria for assessing these factors. Water quality metrics were previously evaluated by labor-intensive laboratory tests and portable devices. On the other hand, contemporary systems—like artificial intelligence and Internet of Things—allow for real-time measurements and alerts of potentially dangerous circumstances. Fish behavior, including swimming activity, depth, acceleration, and water quality, can also be impacted by changes in water quality. [18]

Using techniques like pairwise analysis of correlation matrices, weekly data from two fish ponds in the Lintangsongo smart farming region is gathered over a six-month period in order to minimise dimensionality. Recursive feature elimination (RFE) and XGBoost classification were employed as feature selection techniques. The top two predictors are found to be ammonium and calcium, both of which are essential for sustaining the paired culture system and encouraging the healthy growth of water spinach and Nile tilapia fish. Nutrient distribution and detection continue until the target amounts are obtained. Nutrient value was assessed using Vernier sensors, and a closed-loop nutrient delivery system was added. [19]

Marine life in aquariums produces harmful impurities and proteins that pose a significant threat to their survival and health. Removing these impurities is crucial for maintaining a clean environment for marine life. Regular testing of water quality parameters as turbidity sensors, can help aquators avoid manual work and create a balanced system for fish survival. An IoT-based solution to monitor water quality and provide wireless control using WIFI. This low-cost electronic sensor-level detection system is developed to monitor the health of fish and provide an automated solution that is wirelessly controlled using WiFi. [20]

A. Problem Statement:

- Delay continuously monitoring of aquarium and the water quality in the traditional method.
- Maintaining proper cleaning in the water of aquarium.
- To analysis the water parameters like PH, Temperature and Turbidity.

3. PROPOSED METHODOLOGY

The proposed model is designed for continuous monitoring of aquarium by means of temperature, PH, and turbidity using sensors, as well as cleaning and controlling actions like cleaning and refilling the aquarium using actuators. The system is controlled by a wifi-based controller for IoT applications.

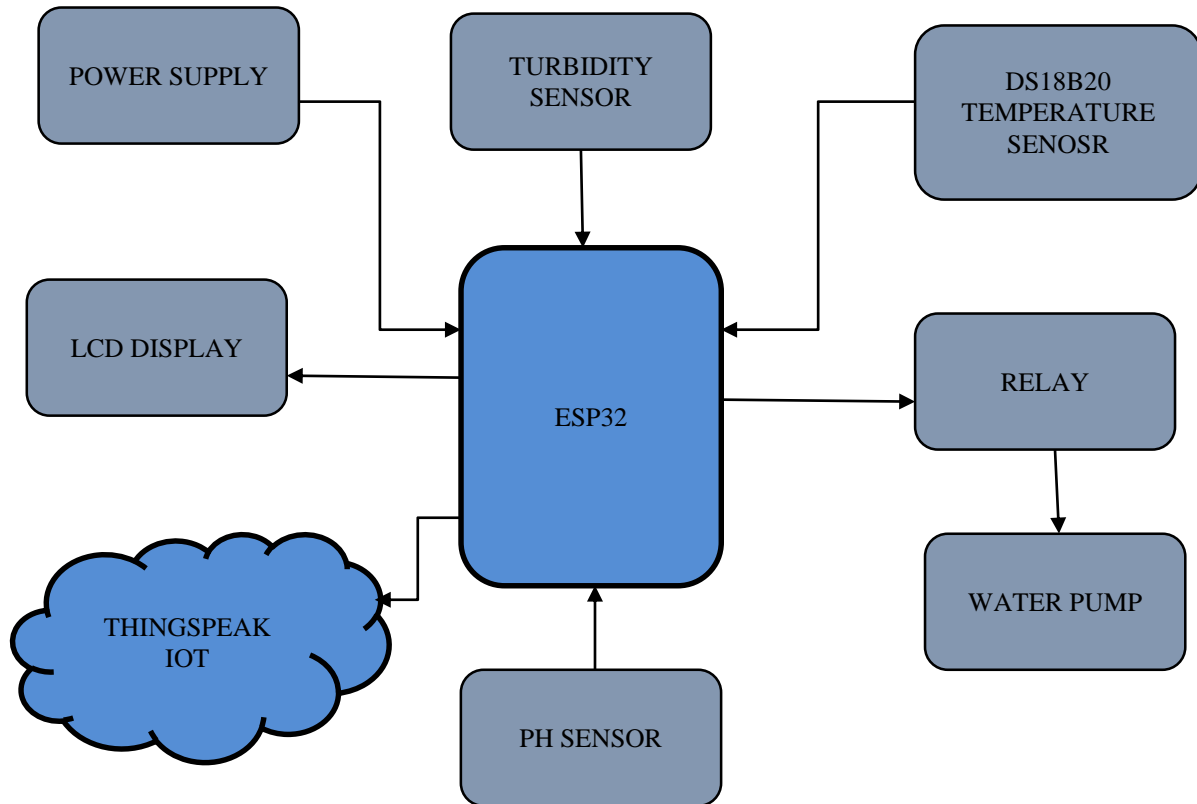

Fig. 1. Block diagram of the proposed IoT-Enabled Smart Aquarium Systems

The working process of the model is described by the sensor, such as the PH level sensor, turbidity sensor, and DS18B20 temperature sensor, for the monitoring of parameters such as the temperature of the water, PH level of the water, and the turbidity level of the water. In India, the standard PH level of the freshwater aquarium is about 6.5–7.5, the temperature level is about 18–29 °C, and the turbidity level is not more than 10 NTU. If any parameters exist, the normal level of the water must be changed for fish safety purposes. The process is automatically done by using the water pump. The pump can clean the tank by take out all the water from fish tank, and the refilling of fresh water is also done by the water pump. An LCD display is used to show parameters such as temperature level, PH level, and turbidity level.

The Thingspeak IoT platform is used to display the parameters on the smart phone using the Thingspeak website. The data is displayed in the form of numerical values with their units in the different GUI interfaces available on the Thingspeak platform. The wifi-based controller, as an ESP32 controller, is used to control and monitor the entire model and to upload the data to the cloud-based server, as Thingspeak, by using Inbuilt WiFi in the controller.

The entire model is get power up by the step down transformer with the rectifier circuit, the step-down transformer used to covert 230v AC supply into the 12v AC supply and the 12v AC is converted into the 12v DC supply by the use of H-Bridge rectifier and the capacitor for filtering purpose. The 12v DC is get reduced into the 5v DC by the use of the 5v by the use of voltage regulator circuit.

3.1 PH Sensor

Water pollution, caused by various chemicals, is crucial for human health. Traditional methods like pH indicators, such as phenolphthalein litmus and methyl orange, are insufficient for accurate pH readings. To address this, pH sensors are used as a standard procedure, which measures water quality like acidity and alkalinity. These simple devices help overcome the limitations of traditional methods and provide more accurate readings.



Fig. 2. PH Sensor

A pH sensor is a crucial tool for measuring pH in water quality monitoring, detecting alkalinity and acidity in water, and other solutions. A well-designed monitoring system can reduce water waste, save energy, meet supply chain sustainability requirements, prevent downtime, maintain a healthy workplace, and reduce hazardous chemical use, all of which can be achieved through a well-managed monitoring system.

3.2 DS18B20 Temperature Sensor

For particular devices, the DS18B20 temperature sensor gives 9- to 12-bit temperature data. It interfaces with an internal CPU using a single data line and the one-wire bus protocol. It has uses in consumer goods, industrial systems, thermostatic controls, thermally sensitive systems, and thermometers. It also does away with the requirement for an external power source



Fig. 3. DS18B20 Temperature Sensor

The DS18B20 temperature sensor operates similarly to a temperature LM35 sensor, with a resolution ranging from 9-bits to 12-bits. It powers up with a 12-bit default resolution and operates in low-power inactive conditions. Temperature measurement and conversion of Analog to Digital can be done using the convert-T command, with output temperature information stored in a 2-byte register before returning to inactive state.

3.3 Turbidity Sensor

Water quality is determined using turbidity sensors, which detect the light dispersed by suspended particulates in a water, such as water. For samples with high absorptions of total suspended solids (TSS) and total dissolved solids (TDS), they detect the difference in light intensity from the transmission beam; light scattering is better suited for samples with low concentrations. To minimize external light usage, turbidity sensors should be used with a minimum amount of light.



Fig. 4. Turbidity Sensor

A turbidity sensor measures the scattering of light in water samples by shining light into them and detecting it at specific angles. The amount of scattering is directly related to the water's turbidity, and the sensor converts this data into a turbidity reading, often in Nephelometric Turbidity Units (NTU) or Formazin Nephelometric Units (FNU).

3.4 LCD Display

LCD 16x2 is a Liquid Crystal Display technology used in TVs, computer monitors, smartphones, mobile devices, and tablets. Unlike CRTs, which employ electron diffraction, it uses plane panel display technology and features a backlight that illuminates every pixel in a rectangular network.



Fig. 5. LCD Display

A liquid crystal display (LCD) 16x2 is a type of electronic gadget that uses 5x8 pixels to show 32 characters for data and messages. It can contain a total of 32 by 40 pixels because it contains 16 columns and 2 rows. Because of its accessibility, affordability, and ease of programming, this multi-segment LED power source is frequently utilised in gadgets, do-it-yourself circuits, and electrical projects. There are also 8x2, 8x1, 16x1, and 10x2 display options.

3.5 Water Pump

A water pump is a mechanical and hydraulic pump used in piping systems to generate sufficient force for future use. Originating from early civilization, they are now used in various applications such as housing, farming, municipal, and manufacturing, serving various purposes such as irrigation and power generation.



Fig. 6. Water Pump

A water pump is a portable device used for various household applications, such as draining water from low-flooded areas, refilling swimming pools and bathtubs, and circulating pesticides or fertilizers. Its primary purpose is versatility, making it ideal for a quality pump that can be carefully selected.

3.6 12v Relay

Relays are essential switching devices in electronics, with two key parameters: Load Voltage, Trigger Voltage and Current. Trigger Voltage is the voltage needed to activate the relay, while Load Voltage and Current determine the voltage or current the Normally Close, Normally Open, or Common terminal can withstand. For DC, the maximum is 30V and 10A, so ensure load falls within this range.

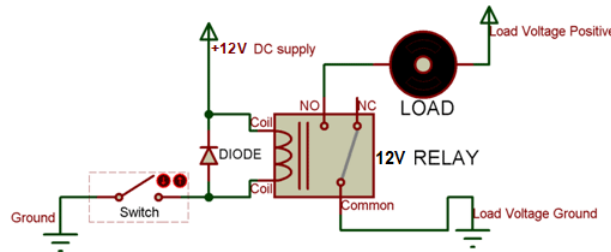

Fig. 7. 12v Relay

The switching element is a transistor, and to shield the switch from high voltage spikes generated by the relay coil, a flyback diode is placed across the coil. The load can be attached to either the Common pin, Normally Open, or Normally Close; Normally Open will keep the load detached prior to the trigger, while Normally Close will make sure the load is connected prior to the trigger.

3.7 ESP32



Fig. 8. ESP32 Controller

An inexpensive, low-power microcontroller board with built-in Bluetooth and Wi-Fi is called the ESP32. With a potent 512 KiB memory Xtensa LX6 processor and an ultra-low coprocessor with 8 KiB memory for deep sleep mode, it has a dual-core processor mechanism. 48 I/O pins, an 8-centimeter Liquid Crystal Display panel, and peripheral interfaces like as Hall Effect, temperature, and capacitive touch sensors are additional parts.

4. RESULT

The Figure 9 shows the kit prototype of the proposed model which contains the sensors as PH sensor, Turbidity sensor and the Temperature and an actuators as relay and Pump motor and controller as ESP32 controller and the power supply consists of Transformer, rectifier and the voltage regulator.

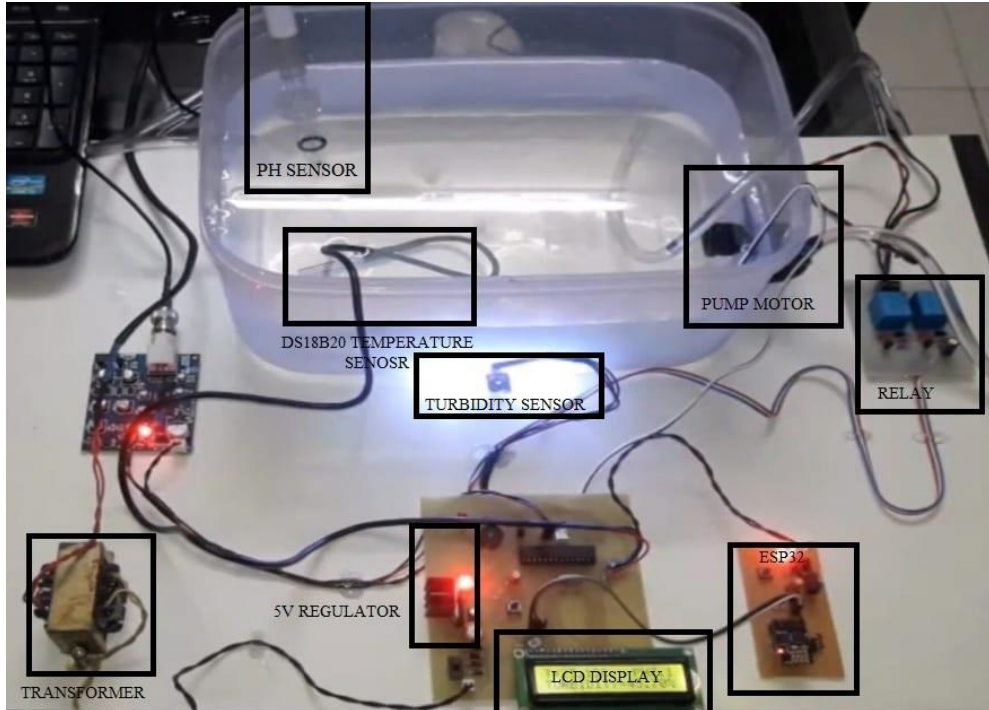

Fig. 9. Prototype model of the proposed model.

Figure 10 shows the PH, Temperature and the turbidity level of the sensors in the LCD display with the units of temperature in Celsius and Turbidity in PPM%.



Fig. 10. LCD Output

Figure 11 shows the level of PH, Temperature and Turbidity of the proposed prototype model in the Thing speak IOT platform with the units of Temperature in Celsius and Turbidity in PPM.

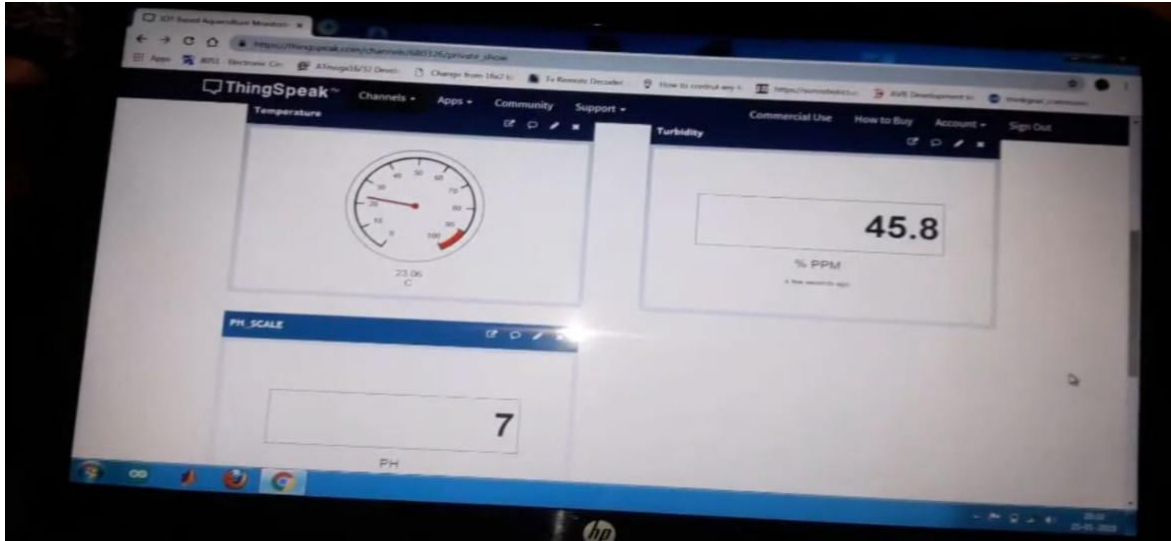

Fig. 11. Output in Thingspeak IOT platform.

5. CONCLUSION

This work proposes to improve the fishkeeping experience by monitoring water pH levels, temperature levels, and turbidity levels. The Internet of Things (IoT) development is particularly beneficial for smartphone users. The model uses pH value, temperature value, and turbidity value coding to monitor water conditions, allowing users to know if the water is comfortable or needs replacement. If it needs automatic cleaning and the refilling process also done. This technology is particularly useful for busy outdoor stations, ensuring their fish's well-being. The experience of introducing new products is valuable for future development and making them more useful for people. The Smart IoT Aquarium is a new venture that is beneficial for fish keepers worldwide. In future, automatic feeding system at particular interval will be implement to improve the work further and the movement of the fish can be monitored to identify the healthy status of the fish in the aquarium.

Funding

The author's paper does not provide any information on grants, sponsorships, or funding applications related to the research.

Conflicts Of Interest

The author's paper explicitly states that there are no conflicts of interest to be disclosed.

Acknowledgements

I wish to acknowledge the facilities provided by Publishing this Research article by "Centre for Networking and Cyber Défense" (CNCD) - Centre for Excellence, Department of Information Technology, Hindustan Institute of Technology and Science, Kelambakkam, Tamil Nadu -603103, India

References

- [1] T. A. Taher, "Development of IoT based fish monitoring system for aquaculture," in *Intelligent Automation and Soft Computing*, vol. 32, no. 1, pp. 55-71, 2022.
- [2] L. K. S. Tolentino, "Development of an IoT-based intensive aquaculture monitoring system with automatic water correction," in *International Journal of Computing and Digital Systems*, vol. 10, pp. 1355-1365, 2020.
- [3] R. Z. Zaharuddin, "IoT-based Automated Maintenance System for Fish Tank," in *Journal of Tomography System and Sensor Application*, vol. 6, no. 1, pp. 20-21, 2023.
- [4] C.-H. Chen, "IoT-based fish farm water quality monitoring system," in *Sensors*, vol. 22, no. 17, 2022.

- [5] M. M. Islam, M. A. Kashem, and J. Uddin, "An internet of things framework for real-time aquatic environment monitoring using an Arduino and sensors," in *International Journal of Electrical and Computer Engineering*, vol. 12, 2022.
- [6] O. A. Nasir and S. Mumtazah, "IoT-Based Monitoring of Aquaculture System," in *MATTER: International Journal of Science and Technology*, vol. 6, no. 1, pp. 113-137, 2020.
- [7] D. M. Ghazali et al., "Smart IoT Based Monitoring System for Fish Breeding," in *Journal of Advanced Research in Applied Mechanics*, vol. 104, no. 1, pp. 1-11, 2023.
- [8] L. C. Han and I. M. B. M. Noor, "Automatic Aquarium Water Change System with Real Time Monitoring Through IoT," in *Journal of Applied Technology and Innovation*, vol. 7, no. 2, 2023.
- [9] N. H. M. Tahir et al., "IoT Based Automatic Aquarium Monitoring System for Freshwater Fish," in *International Journal of Synergy in Engineering and Technology*, vol. 2, no. 1, pp. 125-133, 2021.
- [10] I. I. Mohd et al., "Design and Development of Microcontroller Based Automatic Fish Feeder System," in *Ijesc*, 2020.
- [11] A. S. Shamshulbahrin and I. Ahmad, "Aquarium Monitoring System via IOT," in *J. Engineering Technology*, vol. 10, pp. 13-16, 2022.
- [12] F. Yan and F. Wang, "Intelligent fish tank based on WiFi module," in *Journal of Autonomous Intelligence*, vol. 1, no. 1, pp. 36-43, 2018.
- [13] M. A. S. Noordin et al., "Aquaponic Monitoring System and Fish Feeding with Favoriot," in *International Journal of Interactive Mobile Technologies*, vol. 17, no. 12, 2023.
- [14] W. Sholihah et al., "Design of IoT Based Water Monitoring System (Simonair) For Arwana Fish Cultivation," in *Eduvest-Journal of Universal Studies*, vol. 2, no. 12, pp. 2872-2884, 2022.
- [15] A. Khudoyberdiev et al., "Enhanced Water Quality Control Based on Predictive Optimization for Smart Fish Farming," in *Computers Materials and Continua*, vol. 75, no. 3, 2023.
- [16] N. L. Julida et al., "IoT Based Smart Betta Fish Monitoring system with fish fatality prediction," in *Journal of Physics: Conference Series*, vol. 2641, 2023.
- [17] F. C. Ezetoha et al., "Smart Electronic System for Prevention of Water Quality Problems in Fish Culture," in *European Journal of Engineering and Environmental Sciences*, vol. 7, no. 2, pp. 1-11, 2023.
- [18] P. Lindholm-Lehto, "Water quality monitoring in recirculating aquaculture systems," in *Aquaculture Fish and Fisheries*, vol. 3, no. 2, pp. 113-131, 2023.
- [19] Y. Hendriana et al., "Water Quality Monitoring for Smart Farming Using Machine Learning Approach," in *International Journal of Artificial Intelligence and Robotics (IJAIR)*, vol. 5, no. 2, pp. 81-90, 2023.
- [20] K. S. Ali and A. Shakoor, "Monitoring of Water Quality of Aquarium by using IOT technology," in *Journal of Applied Engineering and Technology (JAET)*, vol. 4, no. 2, pp. 22-34, 2020.